

ECN					
REV	MARK	Reasons for change	Change content	Name	Date
A		First Release		W. Z	2024.06.04

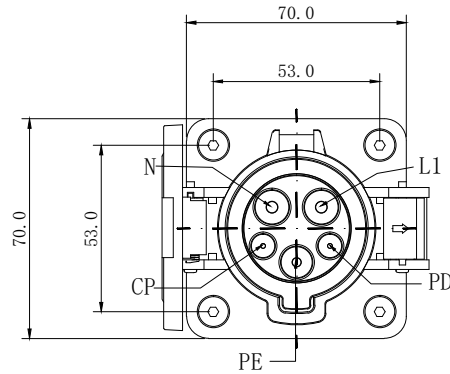

Product labeling

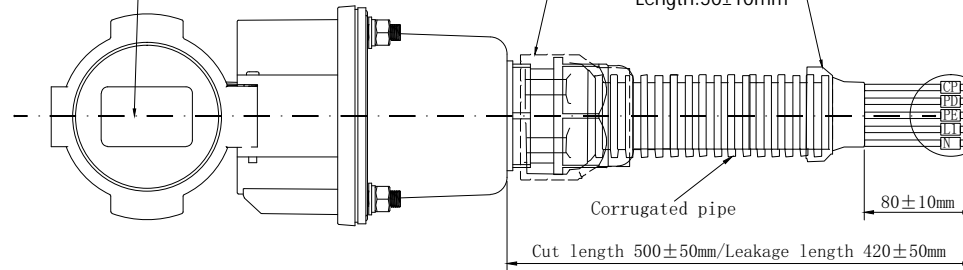

Cables should be fitted with marking tubes

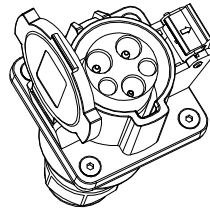

Recommended opening size

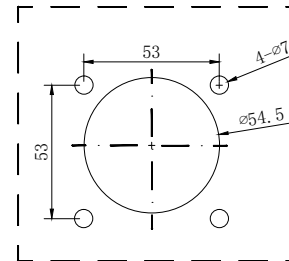

Vehicle inlet wiring diagram

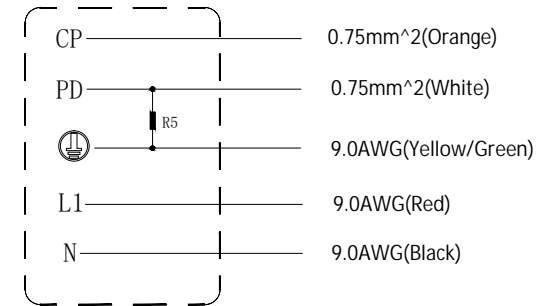

Technical Requirement:

1.Product description: It meets the design and test requirements of SAE J1772-2010;

2.Product performance:Voltage rating 240V  
Current rating 40A  
Dielectric Withstanding Voltage>2000V

3.Resistance: R5, 2700 ;

4.Appearance of the product: No oil stain, burr or other defects affecting the function of the product are found on the surface of the product.

5.Control dimension: The dimension marked is the key dimension,which needs to be controlled.

6.Environmental protection requirements: products meet RoHs requirements;

Customer signature:



Approval	Review	Design	-Unmarked tolerance-		SP VOLT EV CHARGING CABLE CO.,LTD info@spvolt.com	
			Unit: mm	X	±0.30	Name: TYPE1 Vehicle Inlet
			Sheet: A4	X.X	±0.20	Part number:
			Scale:	X.XX	±0.10	Drwaw number: YT5-Y99-030
			Page:	Angle	±1°	
			Material:	Weight :		