

Clients name:  
Clients confirmd:

5m TPU

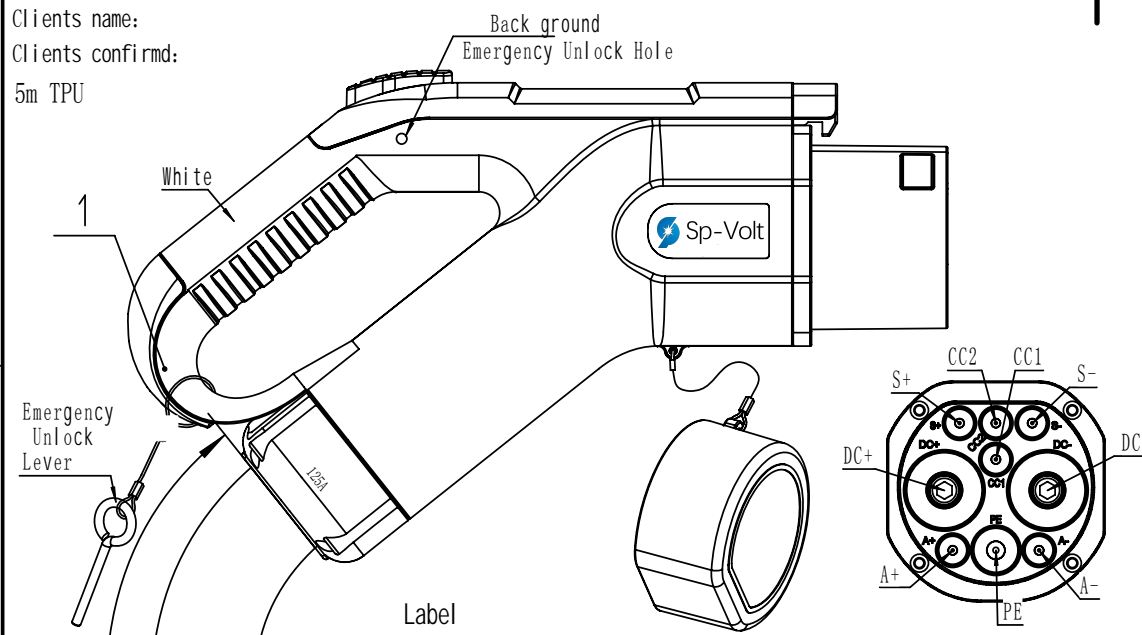

Name: GBT-DC PLUG  
Type: SP-GBT-EV125P  
Size: 125A 1000V DC

wire size color

Function	Color	125A 1000V DC	Terminal block
DC+ (1)	Brown	35 mm <sup>2</sup>	JG35-8
DC- (2)	Blue	35 mm <sup>2</sup>	JG35-8
PE (3)	YellowGreen	25 mm <sup>2</sup>	JG25-8
S+ (4)	White9	0.75 mm <sup>2</sup>	Outer Shielding E7508(Red)
S- (5)	White10	0.75 mm <sup>2</sup>	
CC1 (6)	White11	0.75 mm <sup>2</sup>	
A+ (8)	Red	4 mm <sup>2</sup>	E4009(Red)
A- (9)	Black	4 mm <sup>2</sup>	E4009(Red)
T1+ (10)	Orange1	0.75 mm <sup>2</sup>	E7508(Red)
T1- (11)	Orange2	0.75 mm <sup>2</sup>	E7508(Red)
T2+ (12)	Orange3	0.75 mm <sup>2</sup>	E7508(Red)
T2- (13)	Orange4	0.75 mm <sup>2</sup>	E7508(Red)
EL+ (14)	Purple5	0.75 mm <sup>2</sup>	E7508(Red)
EL- (15)	Purple6	0.75 mm <sup>2</sup>	E7508(Red)
SIGN1 (16)	Purple7	0.75 mm <sup>2</sup>	E7508(Red)
SIGN2 (17)	Purple8	0.75 mm <sup>2</sup>	E7508(Red)
Shielding Layer (18)	Out Cover	Heat Shrink Tubing	

Note: Mark the polarity on the wire harness end.

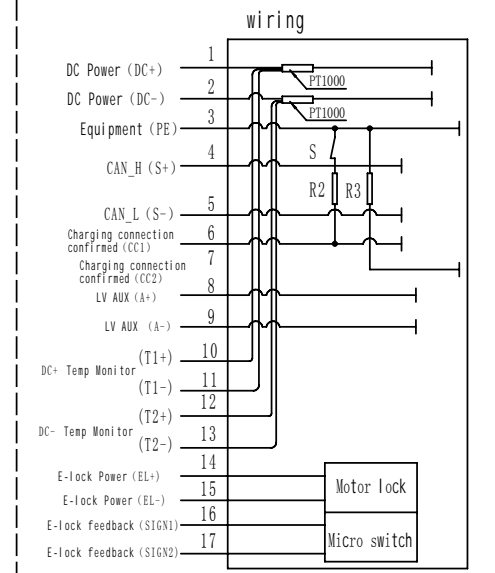

Note: R2 equivalent resistance 1000 1W, R3 equivalent resistance 1000 1W.  
S-hook interlock switch (normally closed), disconnects before the hook lifts 1.5mm.

- Rated Current: 125A
- Rated Voltage: 1000VDC
- Insulation Resistance: >500M (DC1000V)
- Contact Resistance: 0.5m Max

- Dielectric Strength: 3500VAC for 1 minute
- Flame Retardant Rating: UL94V-0
- Insertion/Withdrawal Force: F<140N
- Mechanical Life: 10,000 cycles (no load)

- Protection Rating: IP55 (operating conditions)
- Plastic Parts: Thermoplastic
- Contact Terminals: Copper alloy, silver plated
- Operating Temperature Range: -30°C to +50°C

- Charging plug according to GB/T 20234.3-2015 standard.
- Charging cable 5000mm2×35+1×25+2×4+(4×0.75)(P2)+8×0.75 Black cable

Motor electronic lock control principle DNL101A-T250-02

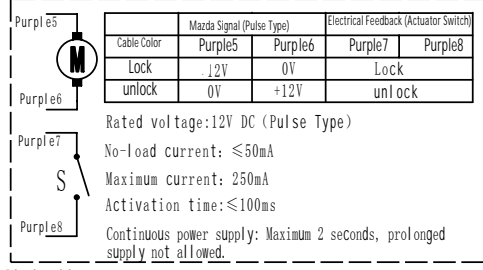

Temperature control method

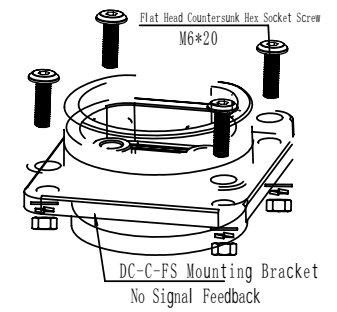
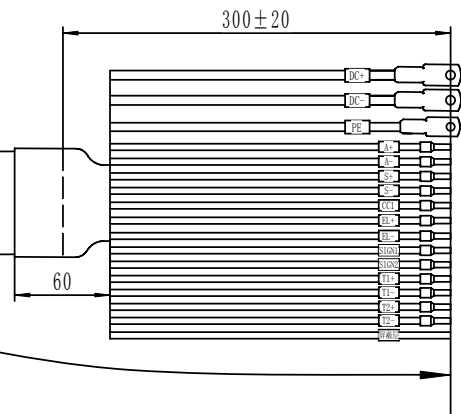
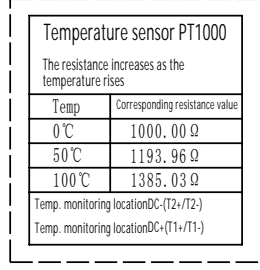

Sp-Volt  
www.spvolt.com

2	Charging Cable	1	2×35+1×25+2×4+(4×0.75)(P2)+8×0.75	Black (TPU)	OLR32248-BK
1	DC GBT Plug	1	AG-GBDC3-C-P	White	
序号	图号	名称	数量	材料规格	外观\备注
pos	DRAW NO.	DESIGNATION	AMOUNT	MATERIAL/SPECIFICATION	APPEARANCE\COLOUR
图样标记	S A	投影标记	SPVOLT EV CHARGING CABLE CO.,LTD info@spvolt.com		
DWG. SYM		PROJ. SYM			
Specification sheet			重量	名称	
			WEIGHT	NAME	
设计	审核	标准化	图号	DC GBT PLUG WITH CABLE	
DESIGNED	CHECK	STD.CHECKED	DRAW NO.	GBT-EV125P	
校对	工艺	批准	品号	纸幅	比例
CHECKED	PROCESS	APPROVED	PART NO.	SIZE	SCALE
				A3	
				第 张	共 张
				SHEET	OF