

TYPE

X

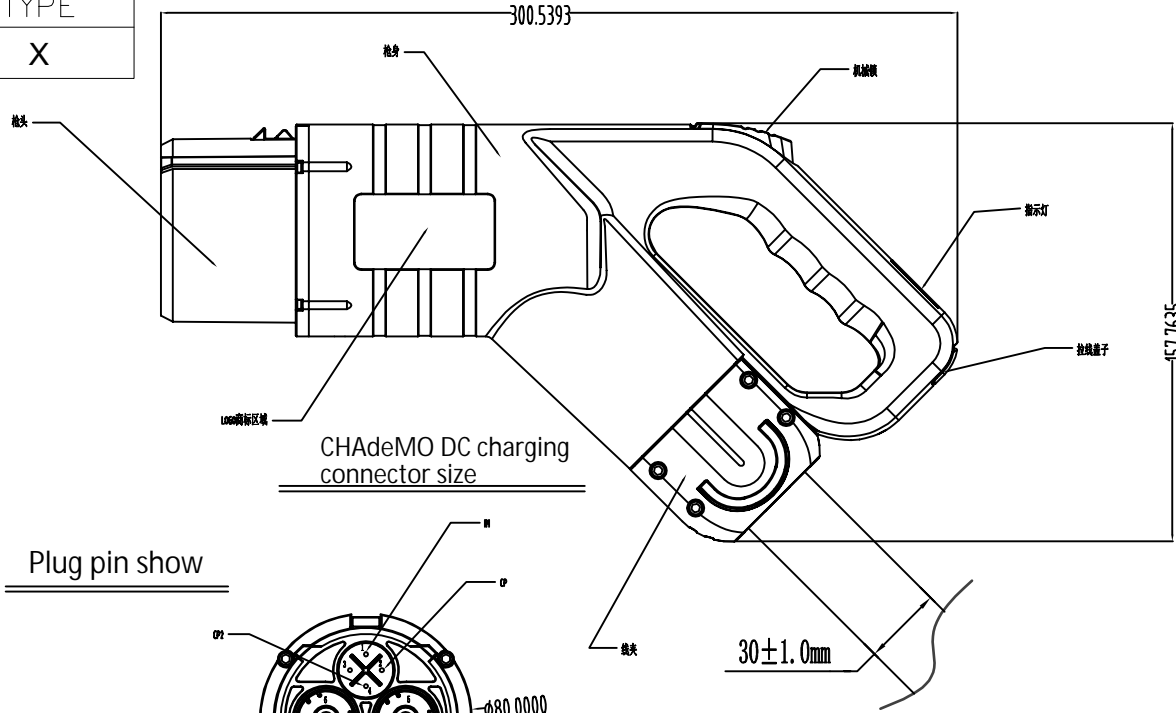

Plug pin show

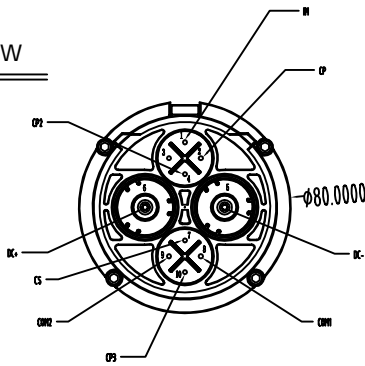

Detail A 2:1  
标签标示线缆的定义

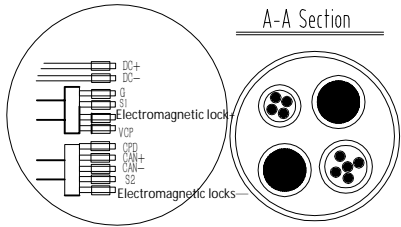

Wiring Diagram

Pin No.	Wire Color	Function
1	0.5mm 蓝色	Ground "IM"
2	0.5mm 蓝色	Charging sequence signal1 "CP"
3	Void	
4	0.5mm 蓝色	Vehicle charging permission "CP2"
5	黑色 35mm	DC(-)
6	红色 35mm	DC(+)
7	0.5mm 蓝色	Connector proximity detection "CS"
8	0.5mm 蓝色	CAN-H
9	0.5mm 蓝色	CAN-L
10	0.5mm 蓝色	Charging sequence signal2 "CP3"

Plug

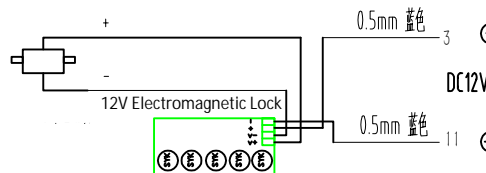

Tail Terminal			
Polarity	mm	Wire No.	Terminal
DC+	35	6	void
DC-	35	5	void
G	0.5	1	E1008
S1 (led+)	0.5	2	E1008
S2 (led-)	0.5	10	E1008
VCP	0.5	4	E1008
CPD	0.5	7	E1008
CAN-H	0.5	8	E1008
CAN-L	0.5	9	E1008
Magnet+	0.5	3	E1008
Magnet-	0.5	11	E1008

Charging Plug Cable: Black TPU material  
Protection Level: IP54

5000±50mm EV CABLE 2X35mm<sup>2</sup>+9X0.5mm<sup>2</sup> DC 1.0KV

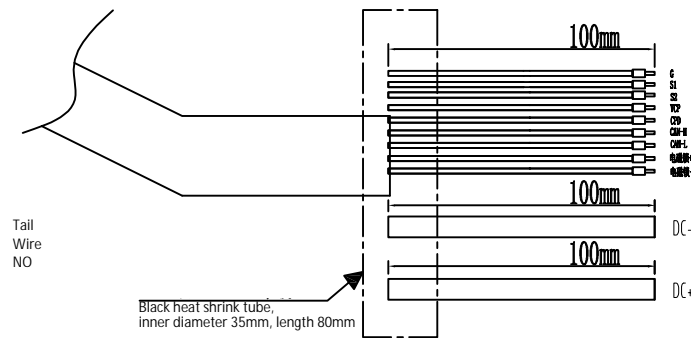

1. Voltage Withstand Requirement: The voltage between DC+, DC- and ground PE, as well as between DC+ and DC-, must be greater than 3500VAC; Test duration is 30s.
2. After terminal crimping, test the pull-out force of the terminal and cable.
3. The product packaging shall comply with the relevant Packaging Specification requirements.
4. The conduction correctness rate shall be 100%.
5. The exposed core wires at the cable end shall be marked according to the plug pin layout, and covered with transparent heat-shrink tubing.
6. The housing shall be marked as per the corresponding SOP.
7. The cable shall be protected with PE film. All exposed wires must be wrapped with heat-shrink tubing.

未注公差 UNLESS OTHERWISE SPECIFIED.  
(1) 所有尺寸为公制 (mm) . All dimensions are in metric (mm)  
(2) 未注公差如下: tolerances are as follows:

.x	±0.5	.x*	±0.5*
.xx	±0.2	.xx*	±0.2*
.xxx	±0.05	.xxx*	±0.1*

制图 DRAWN	日期 DATE
Zhang	2022.06.29
审核 CHECKED	
工艺 ENGINEER	
批准 APPROVAL	
客户 CUSTOMER	

客户编号 PRODUCT NO  
日标直流充电插头总装图 (125A)  
CHAdEMO DC charging connector(125A)  
DWG NO: C-125A  
SPVOLT EV CHARGING CABLE CO.LTD  
www.spvolt.com

文件编号 FSCM NO.	幅面 SIZE	质量 MASS	版次 REV.	比例 SCALE
	A4		02	

SHEET 1 OF 1 NEXT ASSY: